

## Box Filler BF C

For careful filling of potatoes, carrots etc in boxes

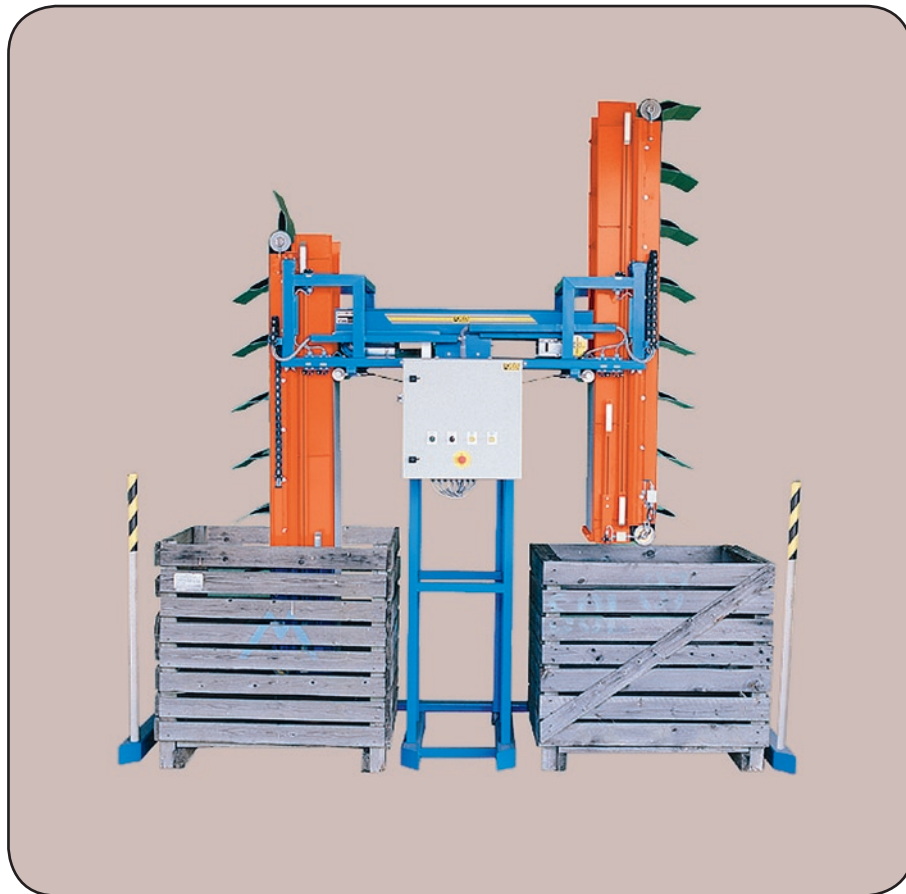

Box filler BF CE

BF C box fillers are available in a number of different versions with various types of fall breakers. All models have automatically reversing conveyors with fall breakers at both ends. A sensor halts filling if the box is not replaced in time. Model BF CG is fitted with double pneumatically controlled fall

breakers.

Model BF CZ has double zig-zag fall breakers.

Model BF CE is fitted with vertical drop elevators to ensure the most gentle filling possible, even with carrots.



Box filler BF CZ with zig-zag fall-breakers.

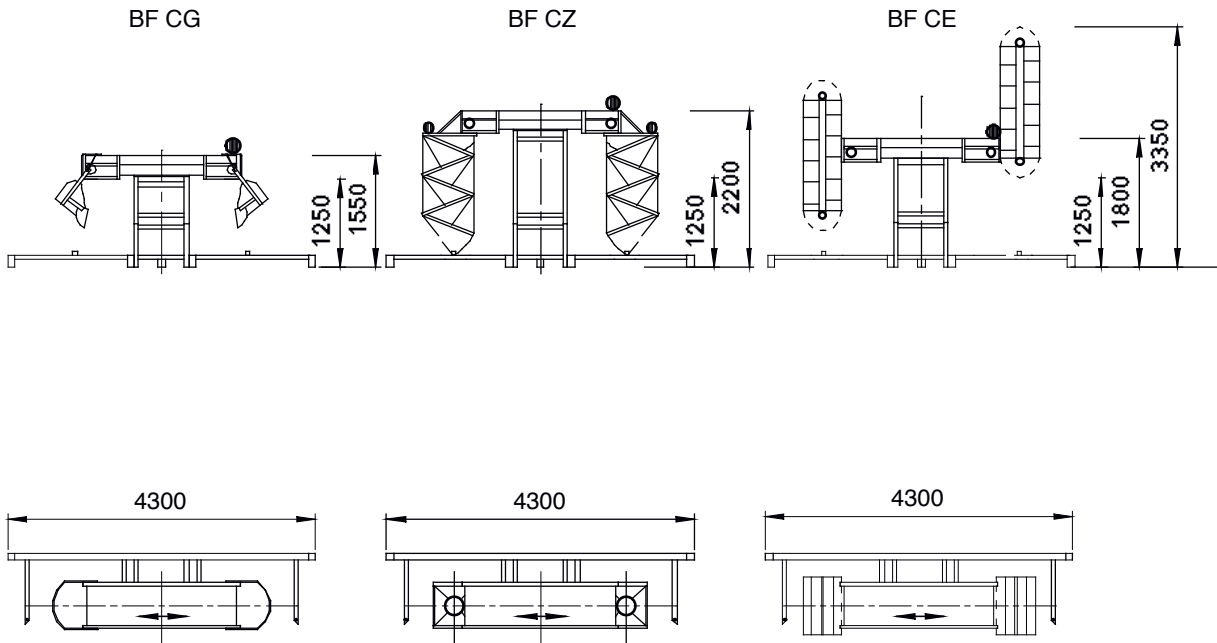

Box filler	BF CG	BF CZ	BF CE
Capacity, t/h	3-30	10-40	10-60
Free output height, mm	1250	1250	1250
Mat width, mm	550	550	550
Conveyor output, kW	0,37	0,37	0,37
Fall breaker output, kW	–	2x0,18	2x0,18/2x0,55
Air supply (optional extra)	25 l/min, 6 bar.	–	–
Electrical connections (all models)	wired for 3-phase N/PEN, 230/400 V, 16 A		

The standard version of the BF CG is fitted with an FB G fall damper with manual depression but automatic lift by means of a gas cylinder. A version fitted with a pneumatically controlled FB G is also available. BF CZ box fillers with automatic zig-zag fall dampers are normally

used only for potatoes, onions and other products with a tendency to roll. The BF CE ensures very careful handling of carrots and similar products as well as potatoes etc, products being transported stationary in saucer-shaped carriers to the bottom of the box, after

which the elevator is raised by a sensor that reads off the level. All BF box fillers can be combined with platform scales for weight-controlled filling. For simpler box fillers and fillers for large sacks, see data sheets Fallbreaker FB and JBF respectively.

- Platform scales for weight-controlled filling
- Narrower or wider elevators
- Conveyors on rails for optimum filling
- Version in stainless steel
- Other versions available on request

Aterförsäljare: